

[5] UNPACKING AND INSTALLATION

1. Copier installation

Improper installation may damage the copier. Please note the following during initial installation and whenever the copier is moved.

Caution: If the copier is moved from a cool place to a warm place, condensation may form inside the copier. Operation in this condition will cause poor copy quality and malfunctions.

Leave the copier at room temperature for at least 2 hours before use.

Do not install your copier in areas that are:

- damp, humid, or very dusty

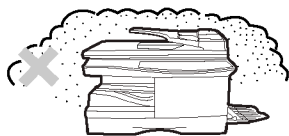

- exposed to direct sunlight



- poorly ventilated

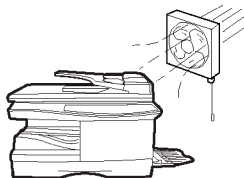

- subject to extreme temperature or humidity changes, e.g., near an air conditioner or heater.



The copier should be installed near an accessible power outlet for easy connection.

Be sure to connect the power cord only to a power outlet that meets the specified voltage and current requirements.

Also make certain the outlet is properly grounded.

Be sure to allow the required space around the machine for servicing and proper ventilation.

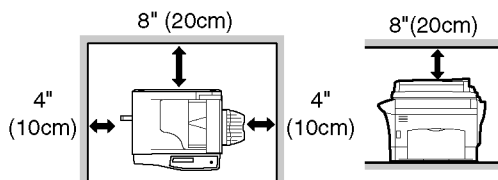

2. Cautions on handling

Be careful in handling the copier as follows to maintain the performance of this copier.

Do not drop the copier, subject it to shock or strike it against any object.

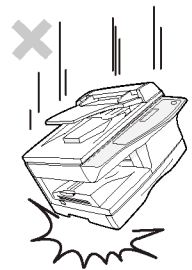

Do not expose the drum cartridge to direct sunlight.

Doing so will damage the surface (green portion) of the drum cartridge, causing poor print quality.

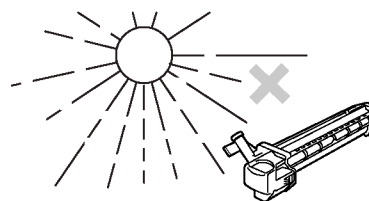

Store spare supplies such as drum cartridges and TD cartridges in a dark place without removing from the package before use.

If they are exposed to direct sunlight, poor print quality may result.

Do not touch the surface (green portion) of the drum cartridge.

Doing so will damage the surface of the cartridge, causing poor print quality.

3. Checking packed components and accessories

Open the carton and check if the following components and accessories are included.

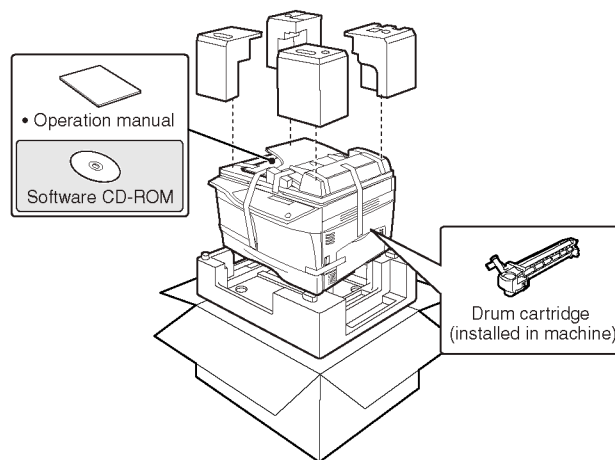

4. Unpacking

Be sure to hold the handles on both sides of the machine to unpack the machine and carry it to the installation location.

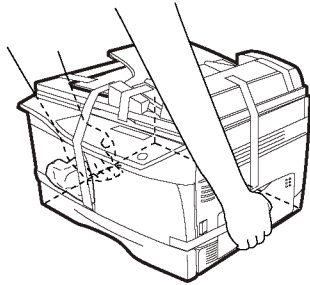

5. Removing protective packing materials

1) Remove all pieces of tape shown in the illustration below and then open the SPF/RSPF and remove the protective materials. Take out the bag containing the toner cartridge.

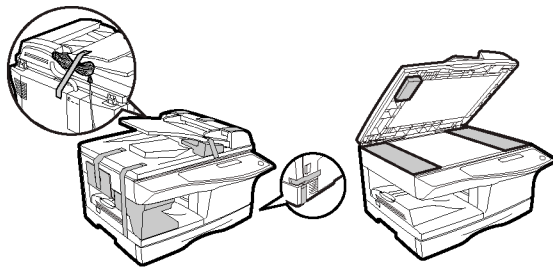

2) Release the scan head locking switch.

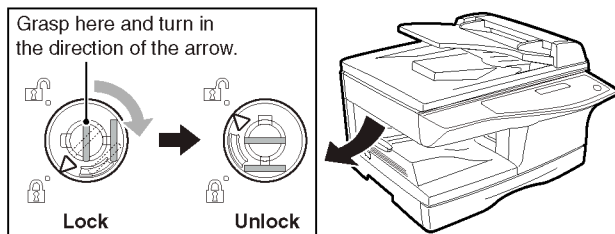

3) Open the bypass tray, and then open the side cover while pressing the side cover open button.

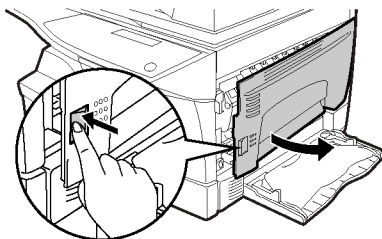

4) Remove the CAUTION tape from the front cover and remove the two protective pins from the fusing machine by pulling the strings upward one at a time.

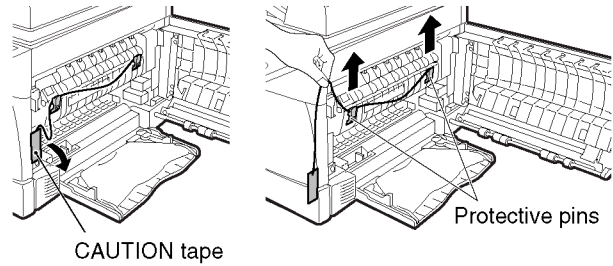

6. Developer unit installation

1) 2) 3) Open the side and front cabinets of the copier.
4) Remove the locking tape of the developer unit.
5) Remove the screw which is fixing the copier and Developer unit.
6) Remove Developer unit slowly from the copier.

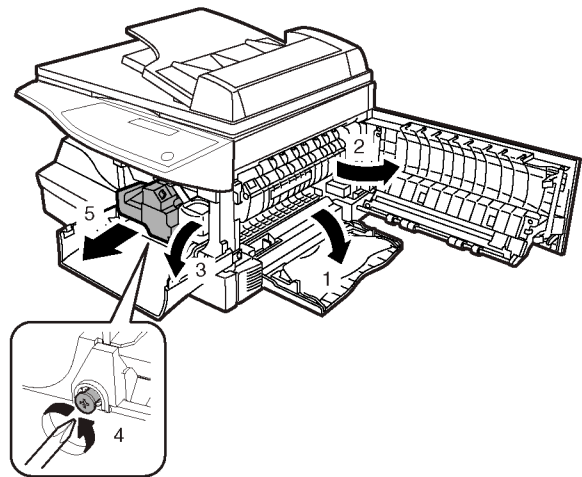

7) Remove the screw (1 pc).

8) Remove Upper developer unit.

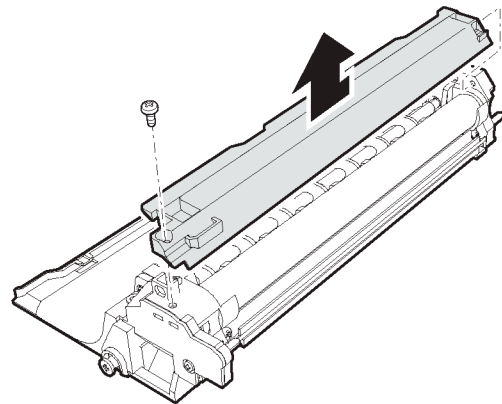

NOTE: If replacing developer ALL the old developer must be removed from the DV unit before adding new developer. The foil bag of developer contains a calibrated concentration. To aid in doing this turn the DV roller clockwise as in #12 below. Use a vacuum cleaner to remove the last particles from the roller.

- 9) Shake the aluminum bag to stir developer
- 10) Supply developer from the aluminum bag to the top of the MX roller evenly.

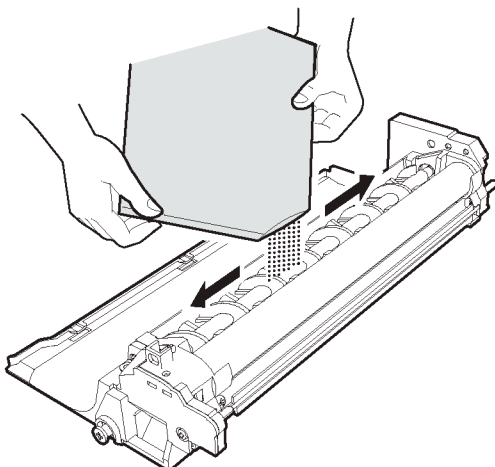

Note: Be careful not to splash developer outside Developer unit.

- 11) Attach Upper developer unit and fix it with a screw.
- 12) Rotate the MG roller gear to distribute developer evenly.

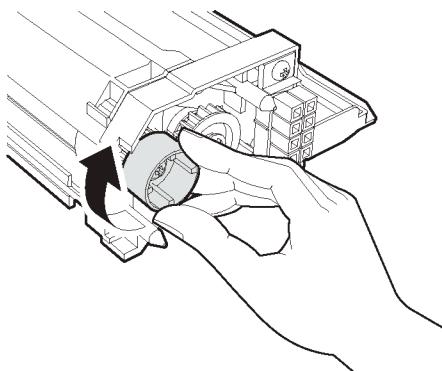

Note: Never rotate the gear in the reverse direction.

Note: When carrying Developer unit, do not tilt it extremely as shown with the arrow in the figure below. (Prevention of splash of developer)

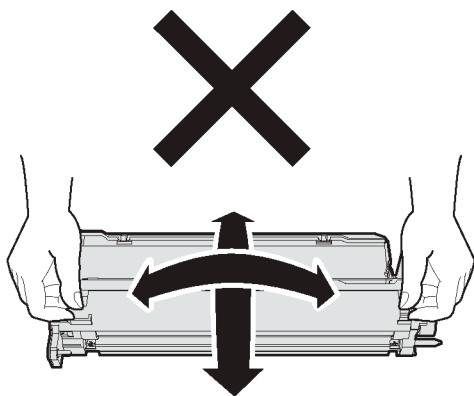

- 13) Insert Developer unit carefully into the copier.
Note: Quick insertion may result in splash of developer. Be sure to insert carefully.
- 14) Confirm that Developer unit is completely inserted to the bottom of the machine, fix Developer unit and the machine with a screw.
- 15) Completion of Developer unit installation

7. Toner cartridge installation

- 1) To prevent against uneven distribution of toner, hold Toner unit with both hands and shake it several times horizontally.

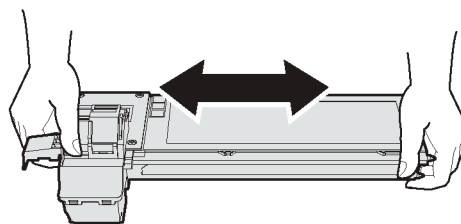

- 2) Hold the section of Toner unit shown in the figure below, remove the packing tape, and remove the cushion.
- 3) Pull out the cushion in the arrow direction.

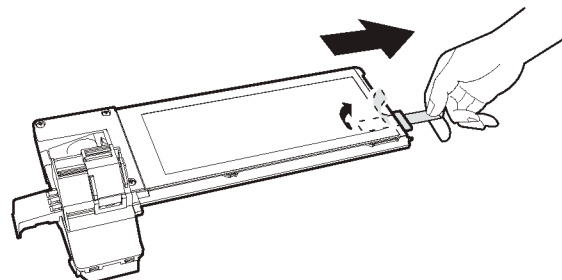

- 4) Insert Toner unit carefully into the copier.
- 5) Insert until the hook is engaged with the copier as shown in the figure below.

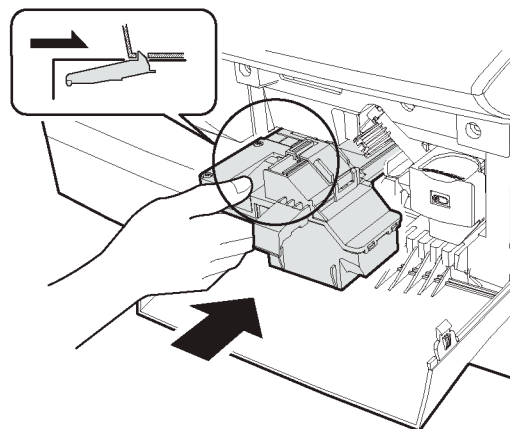

- 6) Pull out the shutter in the arrow direction.

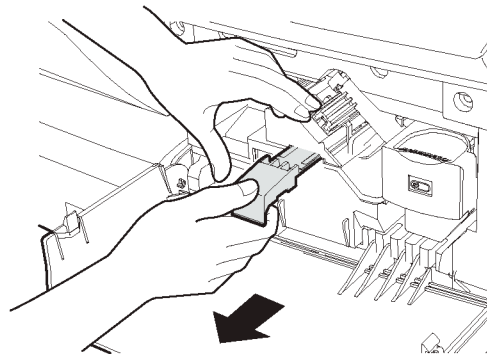

Note: Do not hold and carry the shutter. Otherwise the shutter may drop and Toner unit may drop.

- 7) Completion of Toner unit installation
Close the front and side cabinets.